

P516-099



## ANT400

### OPTIONAL REMOTE ANTENNA MODULE

INSTRUCTIONS FOR  
ANT400-REM-I/O, ANT400-REM-I/O+6dB,  
ANT400-REM-CEILING, ANT400-REM-HALL

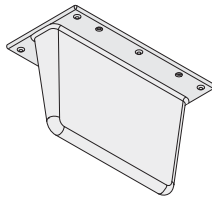
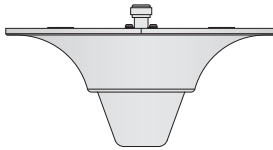
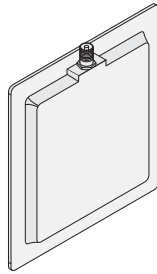

Para el idioma español, navegue hacia [www.schlage.com/support](http://www.schlage.com/support).  
Pour la portion française, veuillez consulter le site [www.schlage.com/support](http://www.schlage.com/support).

# CONTENTS

---

|  |    |
|--|----|
| Overview.....  | 3  |
| Getting Started .....                                    | 3  |
| Model Specifications.....                                | 4  |
| Antenna Location, Safety and Grounding.....              | 5  |
| Location .....   | 5  |
| Safety .....   | 5  |
| Grounding.....   | 5  |
| Lightning Protection.....                                | 5  |
| Connecting the Coax Cable.....                           | 8  |
| Terminating Coax at the PIM400 or WRI400 .....           | 9  |
| Mounting the Antenna .....                               | 10 |
| Mounting the ANT400-REM-CEILING.....                     | 10 |
| Mounting the ANT400-REM-HALL .....                       | 10 |
| Mounting the ANT400-REM-I/O or ANT400-REM-I/O+6dB .....  | 11 |
| Testing .....  | 13 |
| PIM400 .....   | 13 |
| WRI400 with Power Applied .....                          | 13 |
| WRI400 Schlage Button Test.....                          | 13 |
| WRI400 in Construction Mode .....                        | 13 |
| WRI400 Linked to PIM400 and Communicating with ACP ..... | 13 |
| Troubleshooting .....                                    | 14 |
| FCC/IC Statements .....                                  | 15 |



[www.schlage.com/support](http://www.schlage.com/support)



877.671.7011

## OVERVIEW

---

The Schlage Optional Remote Antenna Module is an external antenna that provides a means of increasing the range between a Panel Interface Module and a Wireless Access Point Module (WAPM), or a Wireless Reader Interface and a WAPM using radio frequency (RF). WAPM's include AD-400 locks, Wireless Reader Interfaces (WRI400), Wireless Status Monitors (WSM400) and Wireless Portable Readers (WPR400).

The remote antenna module is connected to the remote antenna connector on a Panel Interface Module (PIM400) or Wireless Reader Interface (WRI400).

- Before installing a remote antenna module, read the user guide for the PIM400 or WRI400 and the WAPM.
- As with all radio systems, interference may be a problem. Some causes of interference are microwave ovens, certain lighting systems, microwave transmitters, or high speed processors for computers.

---

## GETTING STARTED

---



Follow these general steps when setting up a remote antenna module:

1. Install the Panel Interface Module (PIM400) or the Wireless Reader Interface (WRI400) in a designated location within 15 cable feet of where the remote antenna will be located. (For more information on the PIM400 or WRI400, see the installation guides that came with the products, or visit [www.schlage.com/support](http://www.schlage.com/support).)
2. Remove power from the PIM400 or WRI400.
3. Thoroughly check all national and local electrical codes regarding grounding and lightning protection.
4. Familiarize yourself with the information contained in this user guide.

**!** *Save this user guide for future reference.*

## MODEL SPECIFICATIONS

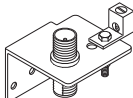
| Remote Antenna Models |                    |  |
|-----------------------|--------------------|--|
| Model                 | Location           | Description/Components   |
| ANT400-REM-CEILING    | Indoor             | Omni-directional ceiling mounted antenna, 15 foot coax cable, and coax whip. For indoor use with PIM400 or WRI400.   |
| ANT400-REM-I/O        | Indoor/<br>Outdoor | Omni-directional flat panel wall or post mounted antenna, 15 foot coax cable, coax whip, grounding kit (MGB+MCA5) required for outdoor applications (sold separately), and articulated wall/post mounting bracket. |
| ANT400-REM-HALL       | Indoor             | Bi-directional ceiling or wall mounted antenna, 15 foot coax cable, and coax whip. For indoor use with PIM400 or WRI400.   |
| ANT400-REM-I/O+6dB    | Indoor/<br>Outdoor | Directional flat panel wall or post mounted antenna, 15 foot coax cable, coax whip, grounding kit (MGB+MCA5) required for outdoor applications (sold separately), and articulated wall/post mounting bracket.      |

| Accessories                 |   | Description/Components   |
|-----------------------------|---|--|
| Item                        |   |  |
| MGB+MCA5 Grounding Kit      |  | Grounding block (shown) and 5 foot coax cable (shown below), non-plenum, N straight plug both ends |
| 15 Foot Cable Non-Plenum    |  | Coax cable, N straight plug both ends  |
| 5 Foot Cable Non-Plenum Kit |  |  |

Note: A grounding block must be electrically connected to an earth ground that meets local code requirements.

## ANTENNA LOCATION, SAFETY AND GROUNDING

### Location

All antenna models in this guide should be located according to the following requirements:

- Locate within 15 cable feet of the PIM400 or WRI400.
- Locate for best RF line-of-sight path with the Wireless Access Point Module(s) WAPM that will be linked to the PIM400 or WRI400.

**Additional location and installation requirements for specific antenna models are provided in the table below:**

| Antenna Model      | Requirements  |
|--------------------|---|
| ANT400-REM-CEILING | <ul style="list-style-type: none"> <li>• Intended for indoor applications.</li> <li>• If local electrical code requires lightning protection, the antenna must be installed with a Grounding Kit. See <i>Accessories</i> on page 4 for more information.</li> </ul>   |
| ANT400-REM-HALL    | <ul style="list-style-type: none"> <li>• The ANT400-REM-HALL antenna's vertical and horizontal centerlines should be at right angles to the target antenna. See <i>ANT400-REM-HALL Radio Frequency Radiation Pattern</i> on page 7 for radio frequency beamwidth radiation pattern specifications.</li> </ul> |
| ANT400-REM-I/O     | <ul style="list-style-type: none"> <li>• Intended for indoor or outdoor applications.</li> <li>• Outdoor applications must be installed with a grounding kit.</li> </ul>  |
| ANT400-REM-I/O+6dB | <ul style="list-style-type: none"> <li>• Local electrical code may require lightning protection for indoor applications. If required, the antenna must be installed with a Grounding Kit. See <i>Accessories</i> on page 4 for more information.</li> </ul>   |
| ANT400-REM-I/O+6dB | <ul style="list-style-type: none"> <li>• The antenna's vertical and horizontal centerlines should be at right angles to the target antenna. See <i>ANT400-REM-I/O +6dB Radio Frequency Radiation Pattern</i> on page 6 for radio frequency beamwidth radiation pattern specifications.</li> </ul>             |

### Safety

**! WARNING - You can be seriously or fatally injured if this antenna comes in contact with electric power lines or is brought in proximity with a high voltage electrical field. For your own safety, use extreme caution when installing this antenna. Keep away from power lines!**

### Grounding

The National Electrical Code (NEC) requires that every antenna installation be properly grounded. Local electrical codes may have additional requirements. Consult the NEC and local electrical codes for information on proper grounding of the antenna system and other antenna regulations.

A Grounding Kit compatible with all antenna models in this guide is available as an accessory. See *Accessories* on page 4.

### Lightning Protection

All antenna models in this user guide are equipped with DC grounding. The only lightning protection required is a Grounding Kit. See *Accessories* on page 4 for a Grounding Kit available for use with all antenna models shown in this guide.

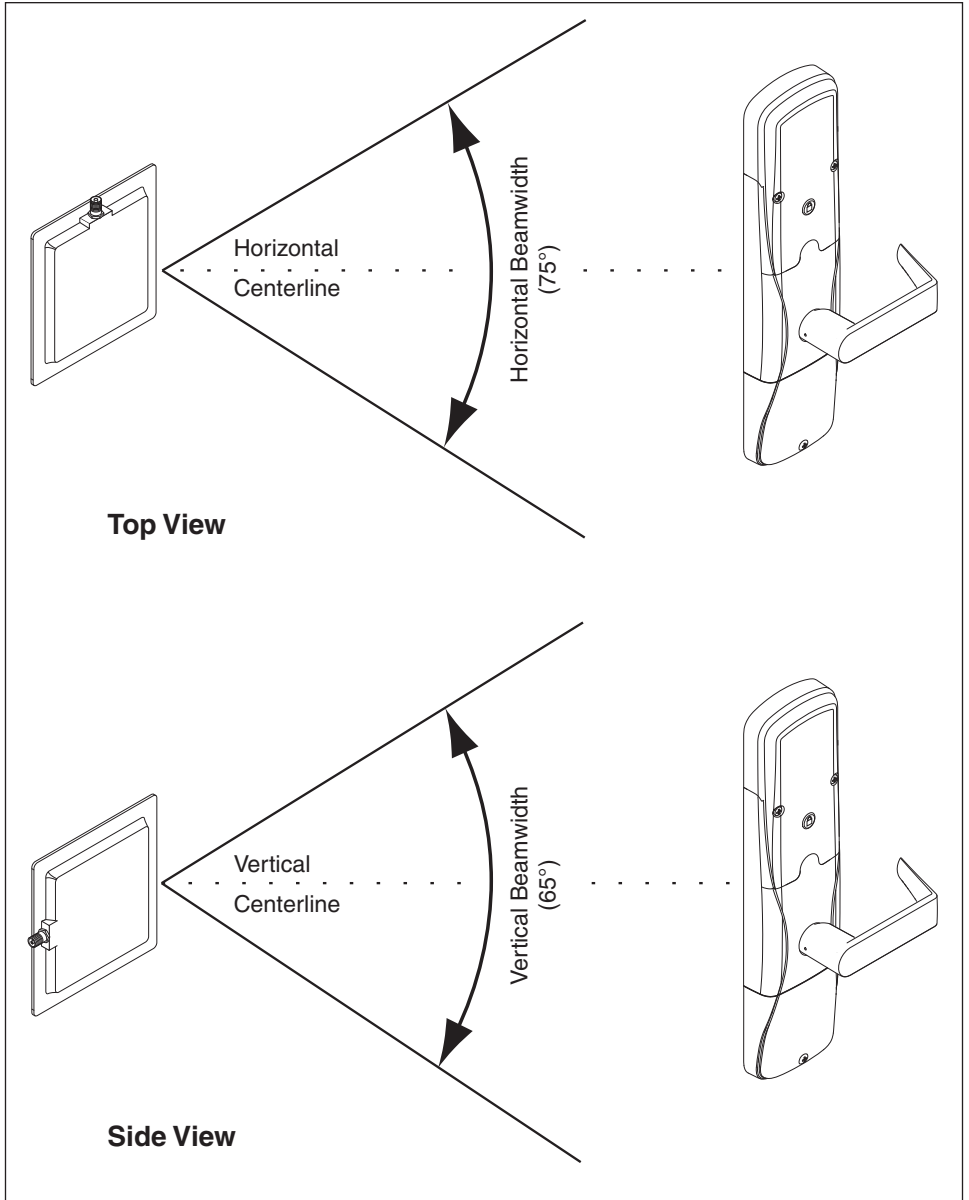

ANT400-REM-I/O+6dB Radio Frequency Radiaton Pattern

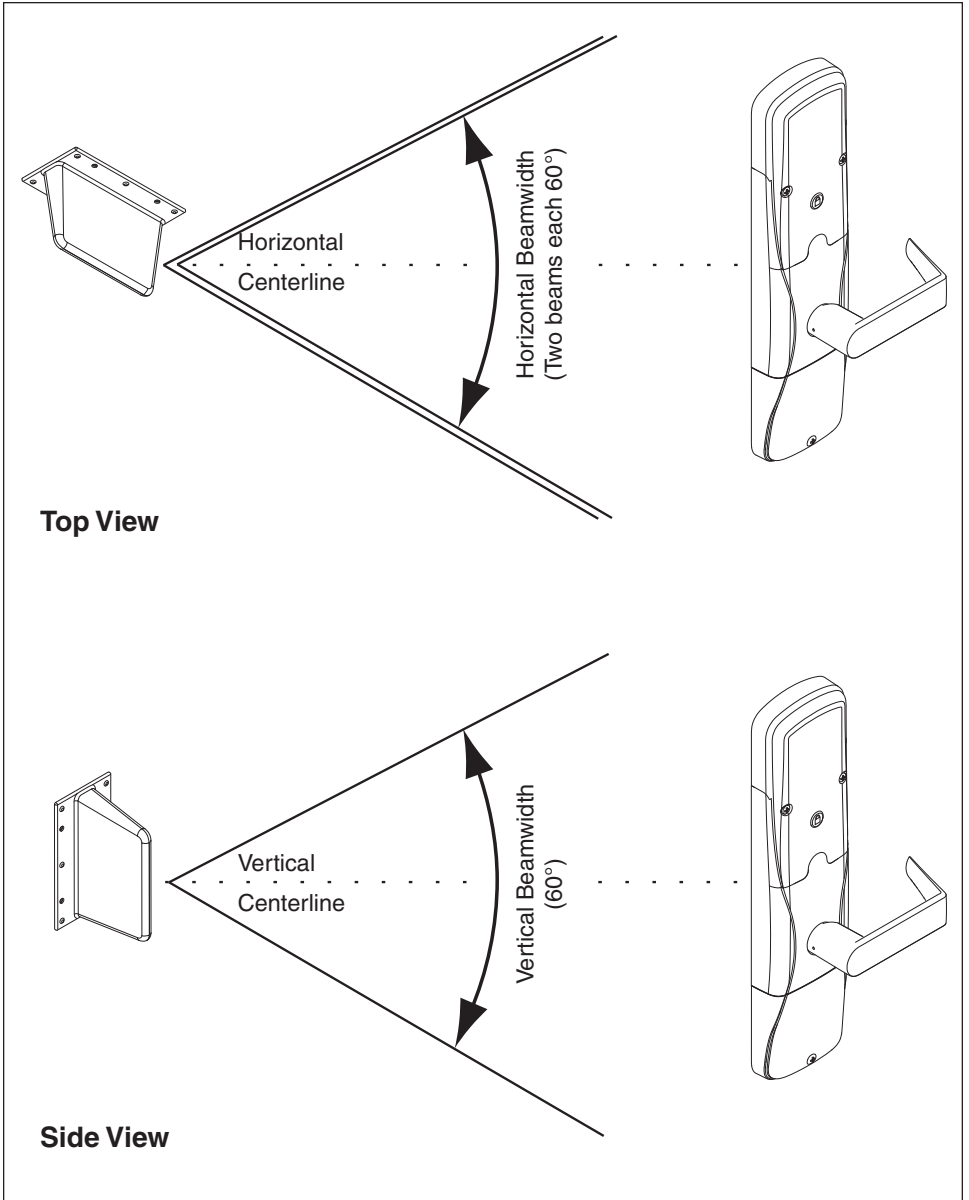

ANT400-REM-HALL Radio Frequency Radiation Pattern

## CONNECTING THE COAX CABLE





The coax cable furnished with all antenna models:

- is suitable for outdoor installation
- should be routed with minimum bends, and when necessary any bend radius should be greater than two (2) inches
- is properly terminated and **should not be cut to length**
- if there is excess coax, it should be coiled no less than eight (8) inches in diameter
- should not have excess coax placed inside or near the antenna, or inside the PIM400 enclosure.

→ *The Grounding Block must be connected to earth ground.*

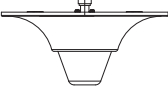
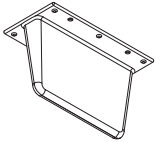
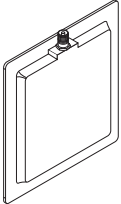
→ *Cable connections must be securely fastened.*

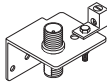
→ *Outdoor antennas that are exposed to weather may require weatherproofing on coax connections.*

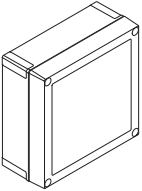
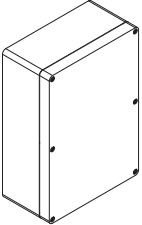
| Antenna   | Application               | Components  |   |  |   |   |
|---|---------------------------|---|---|--|---|---|
| <br>ANT400-REM-CEILING<br><br><br>ANT400-REM-HALL<br><br><br>ANT400-REM-I/O<br>ANT400-REM-I/O+6dB | With lightning protection | <br><br>5 foot coax (non-plenum) N Type male both ends | <br><br>Grounding Kit N Type female bulkhead both ends | <br><br>15 foot coax (non-plenum) N Type male straight plug both ends | <br><br>Coax whip N female bulkhead one end, reverse mcx other end | <br>PIM400<br>or<br><br>WRI400 |

Typical Coax Connections



## TERMINATING COAX AT THE PIM400 OR WRI400

1. Drill a 1/2" hole in the top of the PIM400 or WRI400 enclosure.

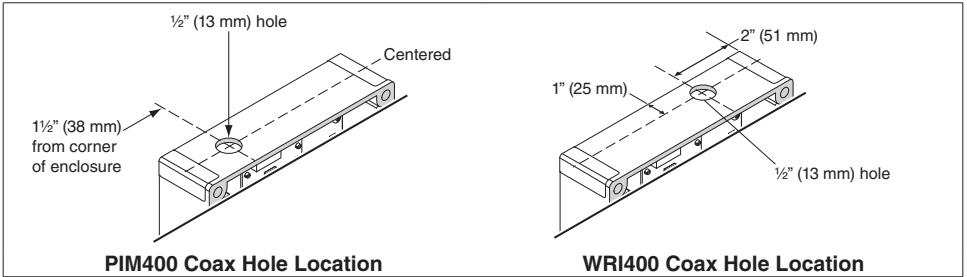

**!** *To avoid damage to electronics inside the enclosure when drilling, use light pressure so that the bit does not penetrate very far when it breaks through the enclosure, or remove electronics from the enclosure before drilling.*

2. Install the N connector through the 1/2" hole.
3. Connect the reverse MCX end of the coax whip to the PIM400 or WRI400 radio board. **The coax whip reverse MCX plug must be perpendicular to the RF board.**
4. Securely fasten the N connector through the 1/2" hole using the lock washer and nut provided.

**!** *Caution - Make sure the MCX plug stays secure.*

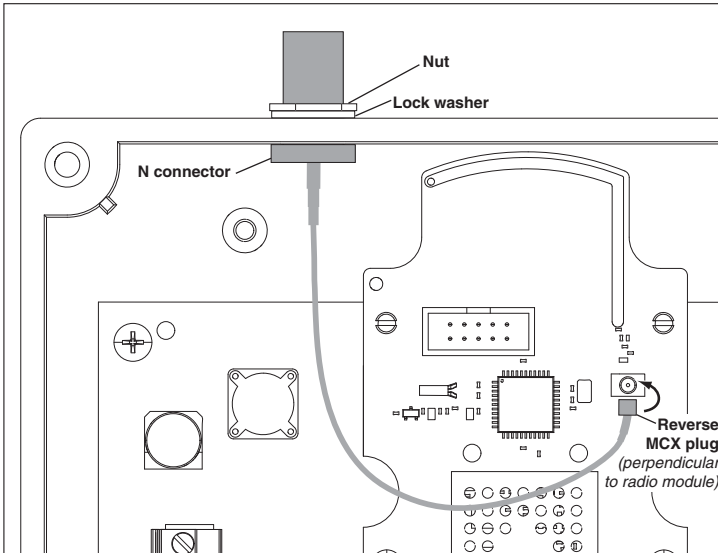

PIM400 shown

## MOUNTING THE ANTENNA

---

### Mounting the ANT400-REM-CEILING

1. Using the antenna enclosure as a template, mark the mounting holes.
2. Fasten the antenna enclosure to the ceiling using screws, and wall anchors if necessary (not provided).

### Mounting the ANT400-REM-HALL

1. Using the antenna enclosure as a template, mark the mounting holes.
2. Position the antenna so that the signal transmission is directed at the WAPM or antenna target, as shown below.
3. Fasten the antenna enclosure to the wall or ceiling using screws, and wall anchors if necessary (not provided).

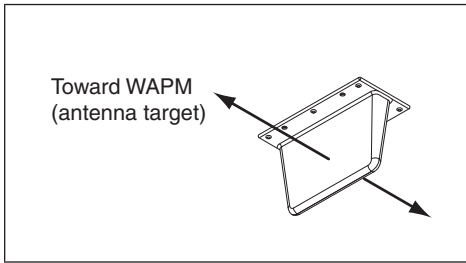

**ANT400-REM-HALL Ceiling mount**

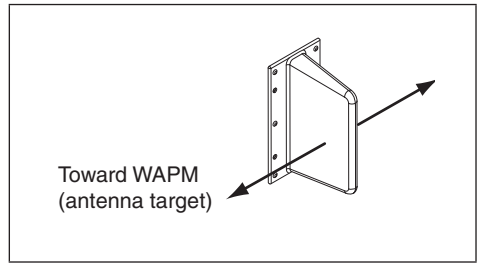

**ANT400-REM-HALL Wall mount**

## MOUNTING THE ANTENNA, Continued

### Mounting the ANT400-REM-I/O or ANT400-REM-I/O+6dB

Follow the steps below to attach the antenna to the mounting kit, and secure the antenna to the wall or a pole.

**TOOLS REQUIRED:**

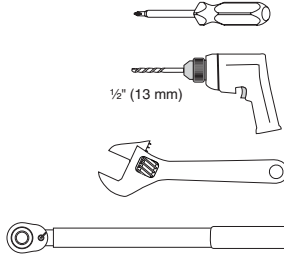

- a. Place the antenna bracket on the back of the antenna as shown. Secure with washers, helical spring lock washers and 1/4-20 hex nuts. **Tighten nuts at a torque of 30 inch lbs.**

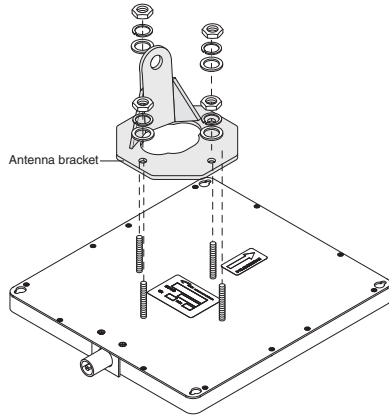

- b. Connect the center portion of the antenna bracket as shown. Secure with a washer, a helical spring lock washer, 5/16-18 x 1 1/4" hex cap screw and 5/16-18 hex nut. **Leave screws slightly loose.**

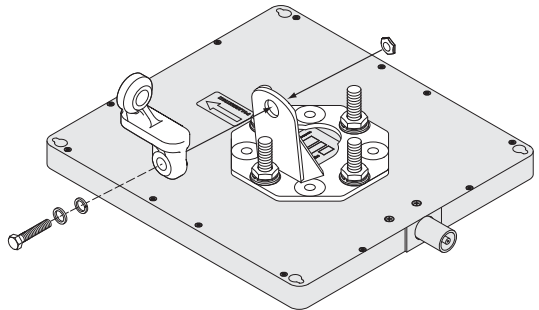

## ANT400 Optional Remote Antenna Module User Guide

c. Connect the mounting bracket portion of the antenna bracket as shown. Secure with a washer, a helical spring lock washer, 5/16-18 x 1 1/4" hex cap screw and 5/16-18 hex nut. **Leave screws slightly loose.**

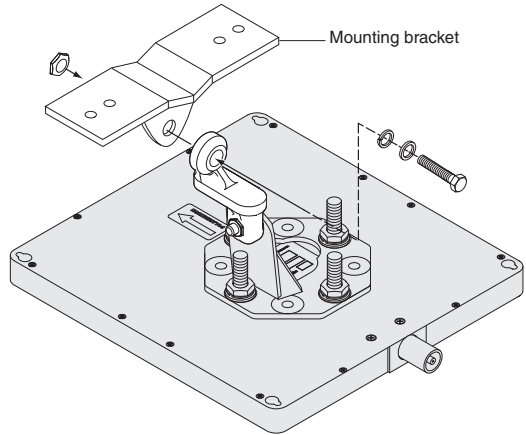

d. Wall Mount: Use the bracket as a template to mark the two mounting holes. Mount to the wall using screws, and wall anchors if necessary (not provided). **Fully tighten the loose screws (steps b and c). Tighten all mounting bracket nuts at a torque of 30 inch lbs.**

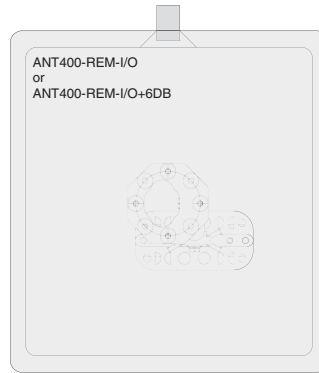

e. Pole Mount: Attach the pole brackets to the pole as shown. Secure the pole brackets with two 5-inch screws, a washer and a helical spring lock washer on each side. Adjust to the desired angle. **Fully tighten the loose screws (steps b and c). Tighten all mounting bracket nuts at a torque of 30 inch lbs.**

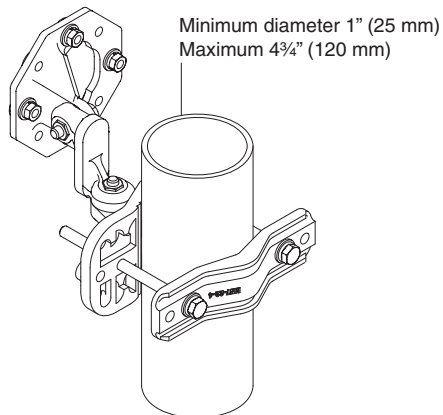

## TESTING

---

Test to verify that the antenna has been correctly installed:

➔ *If you encounter problems while performing the following tests, review the applicable installation guide(s) and correct any problems.*

### PIM400

1. Using the HHD, put the PIM400 into link mode.
2. Put the WAPM into link mode.
3. Verify that the WAPM links properly with the PIM400. (Refer to the label in the PIM400 lid, and/or the PIM400 user guide.)

### WRI400 with Power Applied

1. The LID TAMPER LED will blink green when the WRI400 cover is removed, and will light solid green when the lid tamper switch is pressed.
2. Most readers are designed to function independently of the WRI400. If the reader's LED and beeper performance is irregular or unexpected, refer to the instructions that came with the reader.

### WRI400 Schlage Button Test

➔ *Performing the Schlage Button Test will not result in the loss of any WRI400 settings or programming changes.*

1. While holding the SCHLAGE button, press and release the RESET button.
2. All relays, on-board LEDs, reader LEDs and reader beeper will be active while the SCHLAGE button is pressed.

### WRI400 in Construction Mode

1. After programming a Construction Credential (refer to the WRI400 user guide), present a valid Construction Credential to the reader.
2. The WRI400 Strike relay will activate for the length of the default relock delay. The Aux relay will not activate.

### WRI400 Linked to PIM400 and Communicating with ACP

1. Present a valid credential to the reader.
2. The WRI400's STRIKE relay and STRIKE LED will activate for the relock delay.  
➔ *A valid credential will not activate the AUX relay unless the ACP has given the credential authorization to do so.*
3. If an invalid credential is presented to the reader, the WRI400's RX/TX LED will blink red twice.  
➔ *The ACP may be capable of indicating the WRI400 status for the following:*
  - Lid tamper
  - Request to enter
  - Request to exit
  - Door position switch

Default settings for the above inputs can be configured using the HHD and/or the ACP.

## **TROUBLESHOOTING**

---

- Verify the PIM400 is in link mode. Status LEDs should be alternating green to red continuously.
- Verify the coax in the PIM400 or WRI400 is securely connected to the RF board. See reverse MCX plug connection on page 9.)
- Verify the N Type coax connectors are securely tightened on the PIM400 or WRI400, the grounding kit (if installed), and at the antenna connection.
- Verify the antenna is properly mounted vertically.
- Locate the antenna for best RF line-of-sight path with the PIM400 or WRI400.
- Verify the antenna radiation pattern is properly aligned in the WAPM's direction.
- Verify the WAPM is in link mode.

Find more troubleshooting information at [www.schlage.com/support](http://www.schlage.com/support).

## FCC/IC STATEMENTS

The communication module is a 900 MHz transceiver for electronic locks and non-lock devices. The communication module links the access device to the Access Control Management System, with feedback control to the Access Device via a wireless means. The module contains the embedded firmware implementing the radio physical and data layers. The antennas associated with this module are:

1. PCB trace inverted-L with a measured gain of 5.7dBi.
2. Omni, wall/post, indoors/outdoors.
3. Omni, ceiling, indoors.
4. Directional, wall/post, indoors/outdoors.
5. Bi-directional, ceiling, indoors.

### Specifications of the radio module:

Power Output: 19.6 dBm

Operating Frequency: 906 -924 MHz

Modulation: BPSK

**NOTE:** The intended use of this module is not for the general public. It is generally for industry/commercial use only. This transceiver is to be professionally installed in the end product by Ingersoll Rand, and not by a third party. The Ingersoll Rand AD400 900 MHz Communication Board Module will not be sold to third parties via retail, general public or mail order. In the case of a repair, the transceiver will be replaced by a professional installer.

### Federal Communication Commission Interference Statement

This equipment has been tested and found to comply with the limits for a Class B digital device, pursuant to Part 15 of the FCC Rules. These limits are designed to provide reasonable protection against harmful interference in a residential installation. This equipment generates uses and can radiate radio frequency energy and, if not installed and used in accordance with the instructions, may cause harmful interference to radio communication. However, there is no guarantee that interference will not occur in a particular installation. If this equipment does cause harmful interference to radio or television reception, which can be determined by turning the equipment off and on, the user is encouraged to try to correct the interference by one of the following measures:

- Reorient or relocate the receiving antenna.
- Increase the separation between the equipment and receiver.
- Connect the equipment into an outlet on a circuit different from that to which the receiver is connected.
- Consult the dealer or an experienced radio/TV technician for help.

This device complies with Part 15 of the FCC Rules. Operation is subject to the following two conditions: (1) This device may not cause harmful interference, and (2) this device must accept any interference received, including interference that may cause undesired operation.

### FCC/IC Caution

Any changes or modifications not expressly approved by the party responsible for compliance could void the user's authority to operate this equipment. To comply with FCC/IC RF exposure limits for general population/uncontrolled exposure, the antenna(s) used for this transmitter must be installed to provide a separation distance of at least 20 cm from all persons and must not be co-located or operating in conjunction with any other antenna or transmitter.

### INDUSTRY CANADA STATEMENTS

Operation is subject to the following two conditions: (1) this device may not cause interference, and (2) this device must accept any interference, including interference that may cause undesired operation of the device.

To reduce potential radio interference to other users, the antenna type and its gain should be so chosen that the equivalent isotropically radiated power (e.i.r.p.) is not more than that permitted for successful communication.

This device has been designed to operate with the antennas listed below, and having a maximum gain of 9.3 dBi. Antennas not included in this list are strictly prohibited for use with this device. The required antenna impedance is 50 ohms.

### Approved antenna list

#### Model Number

|          |   |  |
|----------|---|--|
| 23530553 | 1 | Remote antenna, Omni, wall/post, indoors/outdoors        |
| 23530561 | 1 | Remote antenna, Omni, ceiling, indoors                   |
| 23530579 | 1 | Remote antenna, Directional, wall/post, indoors/outdoors |
| 23530587 | 1 | Remote antenna, Bi-directional, ceiling, indoors         |

To comply with IC RF exposure limits for general population/uncontrolled exposure, the antenna(s) used for this transmitter must be installed to provide a separation distance of at least 20 cm from all persons and must not be collocated or operating in conjunction with any other antenna or transmitter.



© 2011 Ingersoll-Rand Company  
P516-099 ENG online Rev. 03/11-b